

ITAL MACHINERY

MACCHINA ITALIANA



**POLYMER
MODIFIED
BITUMEN
(PMB) PLANT**

Polymer Modified Bitumen Plant (PMB) is the ideal solution for all road projects with its high mill performance, compact design, ease of use and economic operation features. With its high production capacity, Polymer Modified Bitumen Plant (PMB) can meet the needs of all road, railway, airport projects and special applications which requires modified bitumen usage.

MAIN FEATURES

- ◆ **160kW high shear mill** is developed for the best working performance with granule polymer types (e.g. SBS) and it ensures polymer modification with less than $<0,3\text{mm}$ grain size in one pass
- ◆ **Long term and problem free operating life** thanks to the mill seal cooling system.
- ◆ **Precision weighing with loadcell integrated process tanks** and strong blending with 2 pieces of 7,5 kW agitator on each processing tank.
- ◆ **Optional:** automatic polymer dosing system.
- ◆ **Optional:** manual or automatic dosing system for solid (ex. sulfur powder) and liquid (ex. PPA) additives.

**POLYMER MODIFIED
BITUMEN (PMB) PLANT**

ITAL MACHINERY

MACCHINA ITALIANA

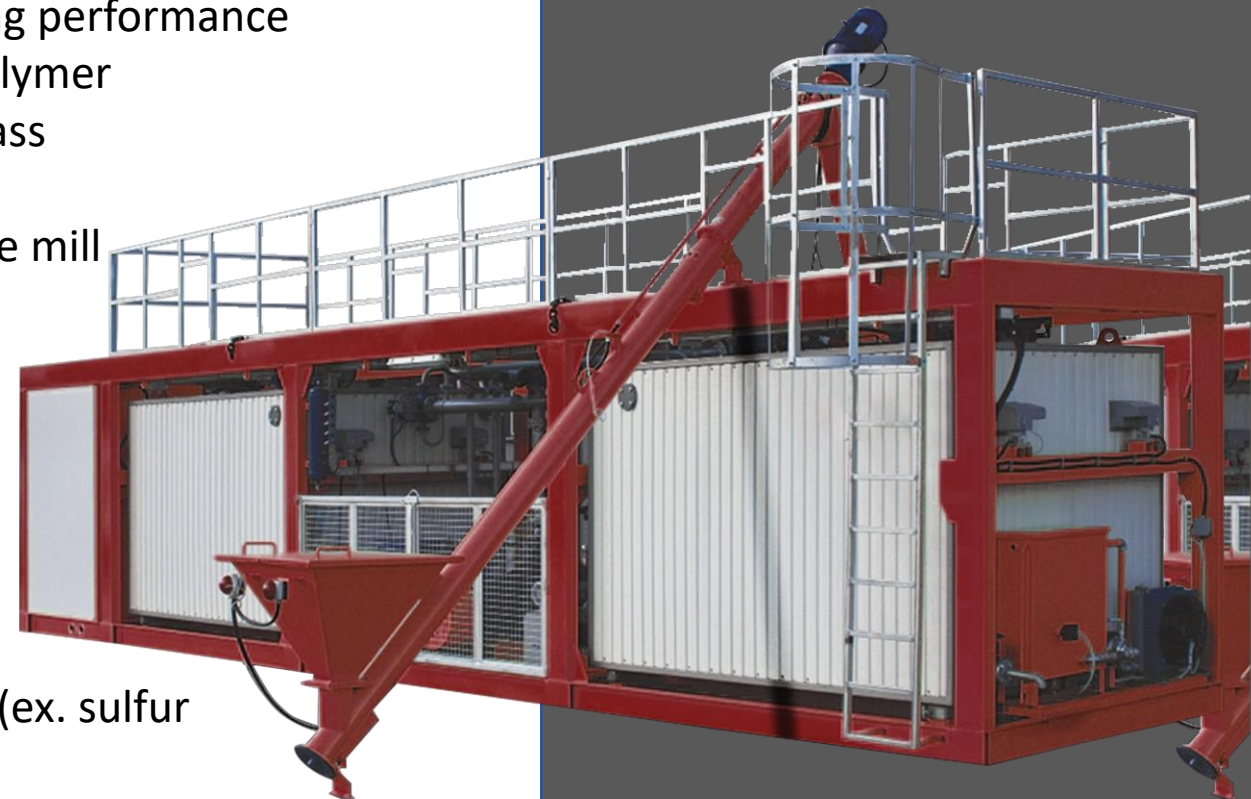

TYPES AND FEATURES

Capacity	Heating	Transp.	Polymer Dosing System	Control System
15 t/h	Thermal Oil	1x 40' OT or 1x TIR	1x manual with ready weighed bags and/or 1x automatic with BigBag	PLC – computer control full automatic & semiautomatic conventional
30 t/h	Thermal Oil	2x 40' OT or 2x TIR	2x automatic with BigBag	PLC – computer control full automatic
20 t/h	Thermal Oil	1x 40' FL or 1x TIR	1x manual with ready weighed bags and/or 1x automatic with BigBag	PLC – computer control full automatic & semiautomatic conventional
40 t/h	Thermal Oil	1x 40' FL & 40' OT or 2x TIR	2x automatic with BigBag	PLC – computer control full automatic
15 t/h	Electrical	1x 40' OT or 1x TIR	1x manual with ready weighed bags and/or 1x automatic with BigBag	PLC – computer control full automatic & semiautomatic conventional

GENERAL SPECIFICATIONS

- ◆ **Plant fitted** into containerized body for stronger structure and easy transportation.
- ◆ **Feeding pump** (pump that transfers bitumen from service tank to PMB tank) is included in the package.
- ◆ **Integrated** control cabin.
- ◆ **Double control system:** semi-automatic & PLC controlled full automatic.
- ◆ **Universal design** for installation of piping connections and screw conveyor on both sides of the plant.
- ◆ **No.2 weighing & mixing** tanks with heating jacket and both mixer tanks equipped with No.2 agitators. By jacket heated system on the tanks, adhesion of polymer granules to dead zones is minimized and it's easy to clean.
- ◆ **Both weighing & mixing** tanks equipped with loadcells for proper weighing of the bitumen.

**POLYMER MODIFIED
BITUMEN (PMB) PLANT**

ITAL MACHINERY
MACCHINA ITALIANA



GENERAL SPECIFICATIONS

- ◆ **Long-lasting and problem-free** use with the cooling system for soft packing seals.
- ◆ **No.2 WAM automatic polymer** feeding system for ready weighed polymer bags.
- ◆ **No.1 high shear mill**, new generation mill with an improved design for smaller particle size and higher productivity.
- ◆ **Universal design:** there are pipe installation inlet and coil connection points on both sides of the plant. In this way, it does not matter bitumen tanks are on the right or left side of the plant.
- ◆ **Top quality electrical** and electronic components for reliable & problem free operation.

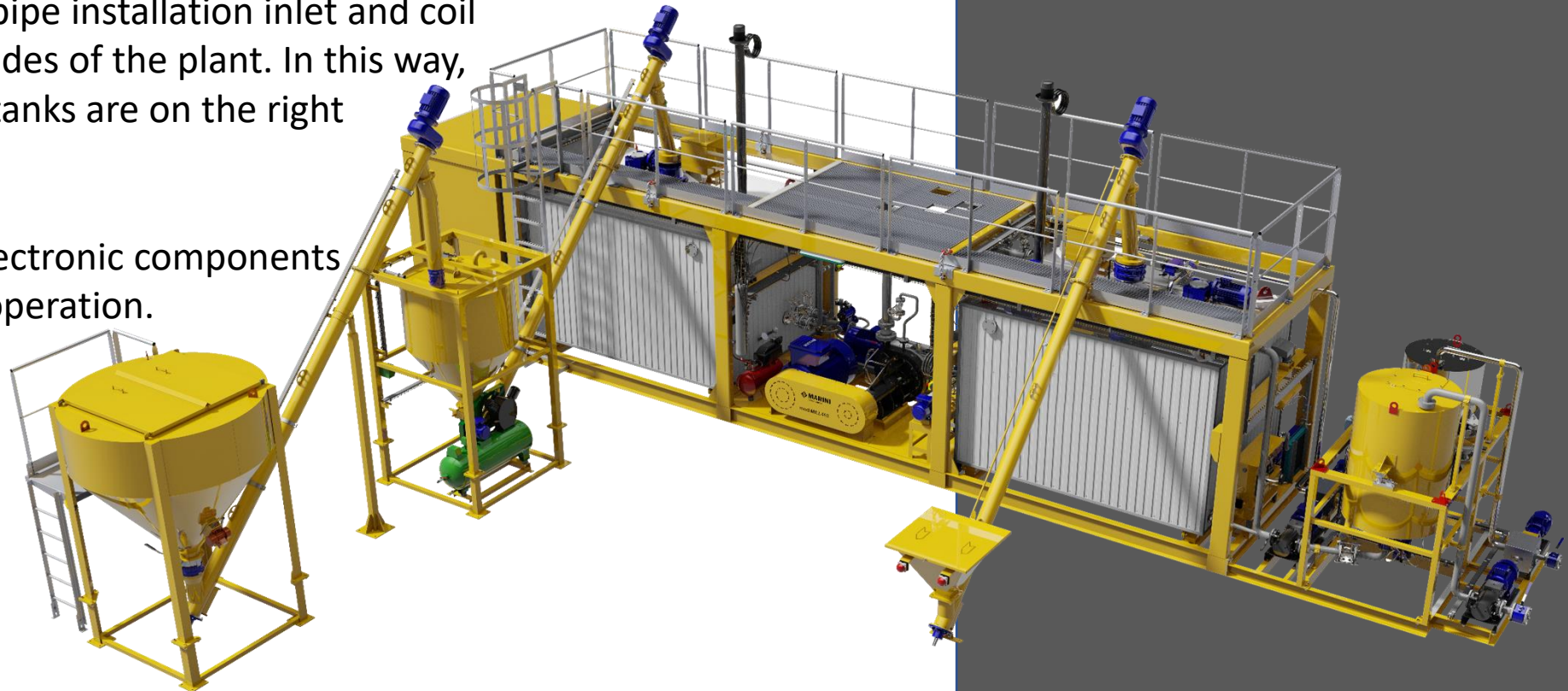

POLYMER MODIFIED
BITUMEN (PMB) PLANT

ITAL MACHINERY
MACCHINA ITALIANA

PRODUCT OVERVIEW - FLOW CHART

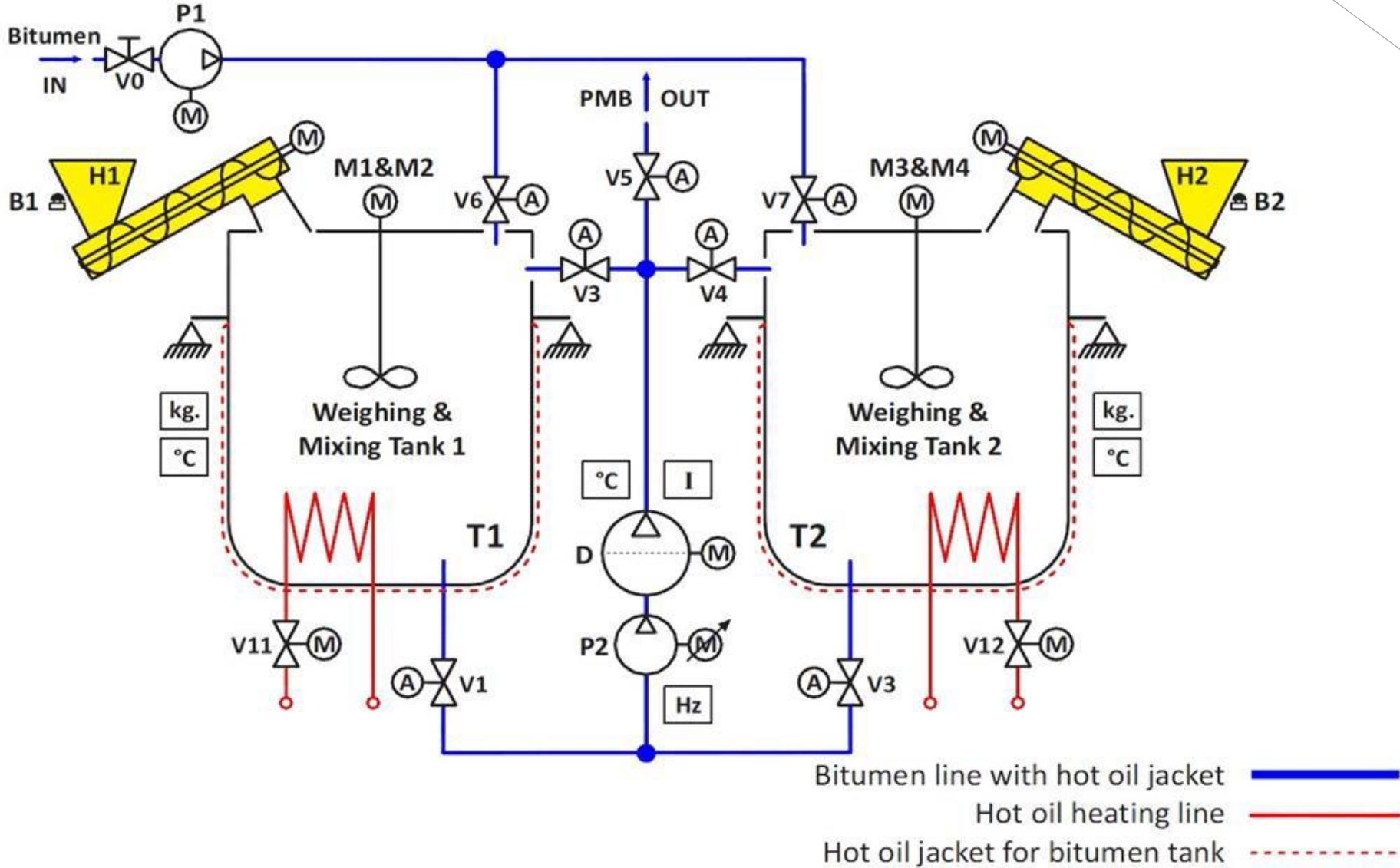

CONTACT US



italmachinery.com.ua



sales@italmachinery.com.ua



+38 (067) 271 61 61

+38 (067) 371 61 61

+38 (067) 801 77 00

+38 (096) 449 32 08



facebook.com/italmachinery



[@italmachinery](https://instagram.com/italmachinery)



[Ital Machinery](https://www.youtube.com/italmachinery)

ITAL MACHINERY
MACCHINA ITALIANA

